



# LIFTA HOME LIFT



Lifta 

# Lifta Mobility Solutions

Lifta South Africa is one of the most experienced Home Lift companies in the country. As a family owned and run organisation, we are proud to call ourselves the German market leader for residential mobility solutions. Established 40 years ago, Lifta is proud to have installed more than 130.000 lifts worldwide.

Lifta offers several mobility solutions for different purposes. Still unsure? One of our experts will recommend the most suitable lift type for your situation.

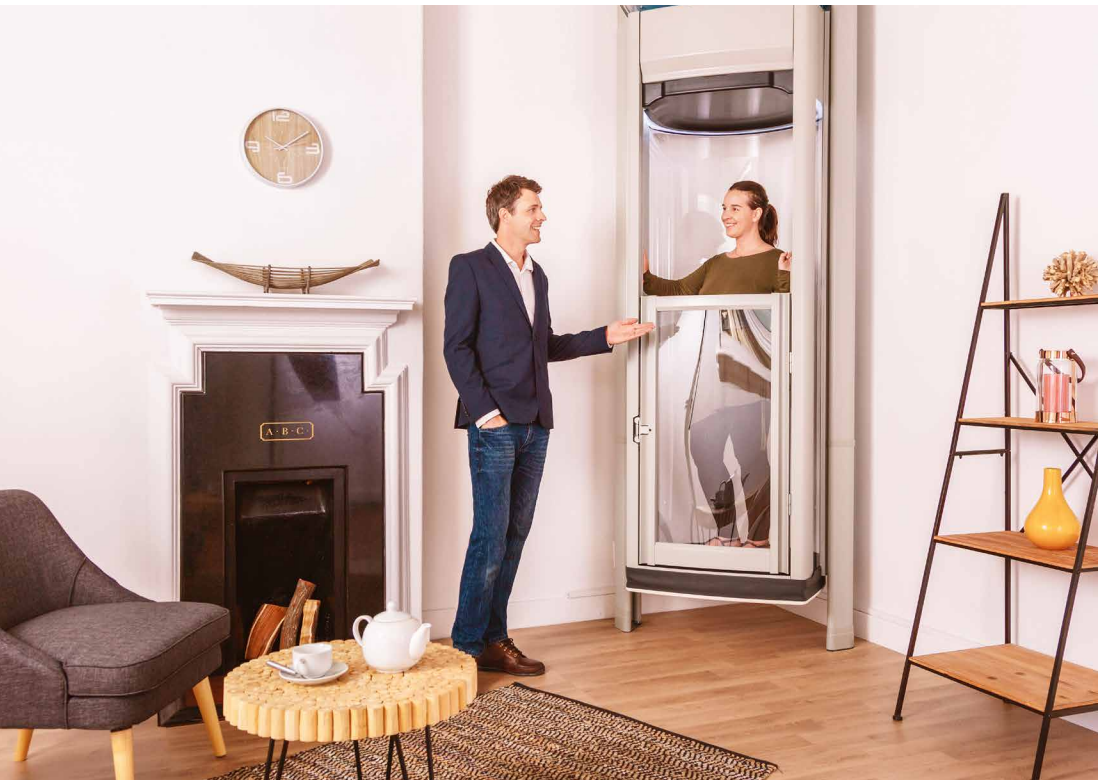

# Introducing the Lifta Home Lifts

LIFTA DUO



LIFTA TRIO



# Comparing the Lifta Home Lift models

	Lifta Duo	Lifta Trio
powered by 220V outlet	✓	✓
Load maximum	180kg	220kg
Roped drum drive system	✓	✓
6 mm Galvanised steel rope	✓	✓
Hold-to-run controls	✓	✓
LED Lights	✓	✓
Wheelchair accessibility	✗	✓
Double sided entry possible	✗	✓
Double Storey Installations (4m)	✓	✓

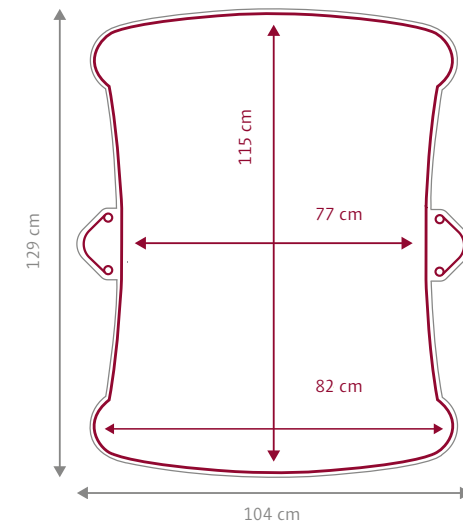
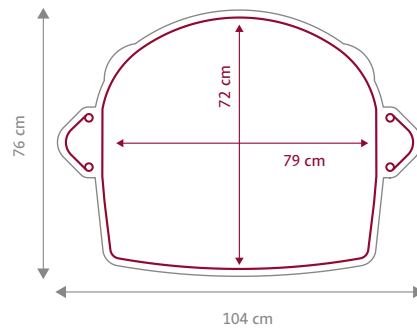



## SOMETIMES LESS IS MORE

The Lifta Duo Home Lift is a unique and innovative domestic lift that can be fitted almost anywhere in your home. This beautiful lift solution can comfortably carry up to two people.

# Lifta Duo

The home mobility revolution is in full swing: The Lifta Home Lift sees unique design meet innovative technology – bringing ease and convenience into your home.



Small footprint



Integrated motor



Runs off your home's main power supply



Room for up to two people



Quiet



Fast installation



Shaft-free, self-supporting system



High quality design



# The advantages of the Lifta Duo



## Easy to operate:

With just up, down and emergency stop buttons, this couldn't be simpler. Locked by a key.



## Small footprint:

Requiring just 104cm x 76cm, the Lifta Duo is a true space miracle. Smoothly glide out of sight at the press of a button.



## Automatic obstruction protection:

Your home lift will automatically stop as soon as it detects an obstruction.



## Solid remote control:

Elegantly designed and easy to use.



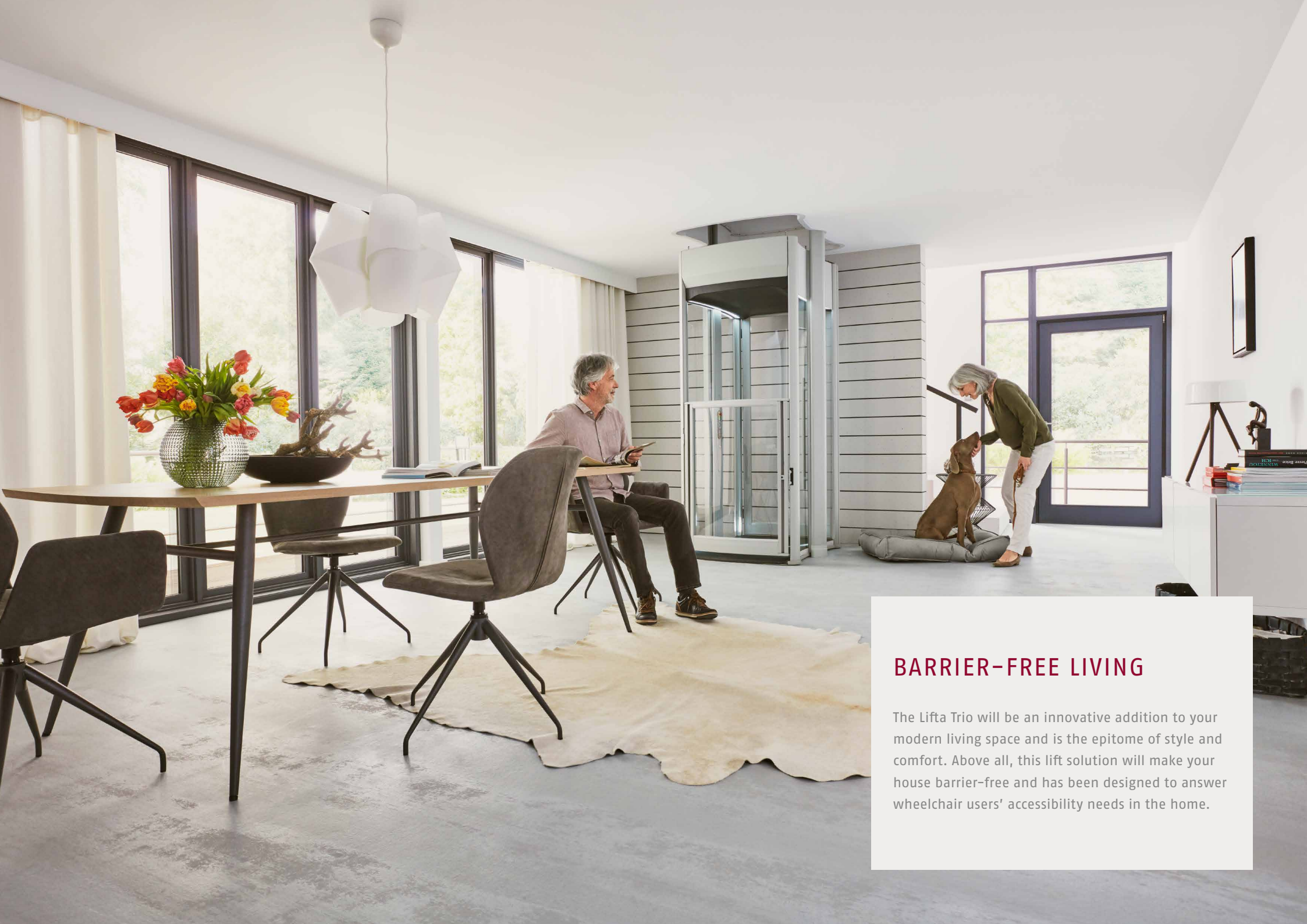

## BARRIER-FREE LIVING

The Lifta Trio will be an innovative addition to your modern living space and is the epitome of style and comfort. Above all, this lift solution will make your house barrier-free and has been designed to answer wheelchair users' accessibility needs in the home.

# Lifta Trio

Special solutions for special requirements. The Lifta Trio impresses with thoughtful details for safety, convenience and wheelchair use.



Runs off your home's main power supply



Quiet



Shaft-free, self-supporting system



Integrated motor



Numerous safety features



Wheelchair-friendly



Access ramp



Space for up to three people



Remote control



Fast installation



High quality design



40 years of service expertise



# The advantages of the Lifta Trio



## Handle:

If required, you can make use of the handle inside of the lift.

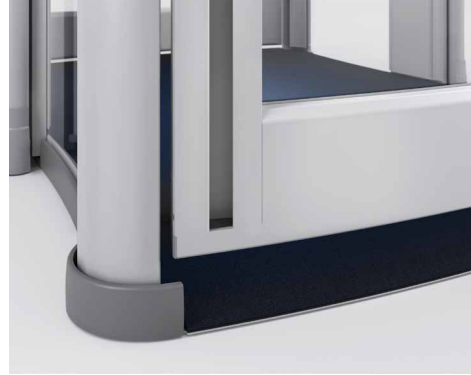

## Ramp:

The built in ramp ensures a comfortable access for any wheelchair user.



## Dual access (optional):

Two doors, so the lift can be exited from both sides, which offers flexibility when it comes to installation and usage.



## Safety lock:

This door is easy to operate and can be opened or closed by pulling and pushing.



# Installation Ideas

Thanks to its slim and sleek design, Lifta Home Lifts can be installed anywhere in your house. Some locations will require alterations, whilst others are straight forward. Of course one of our technical experts will support you in the process of selecting the right location and recommend a feasible spot in your house, considering your preferences and requirements.

Why you are saving space with a Lifta Home Lift:

- 1) Shaftless design
- 2) Lift pit not required
- 3) Machine room not necessary

## VOID SOLUTION

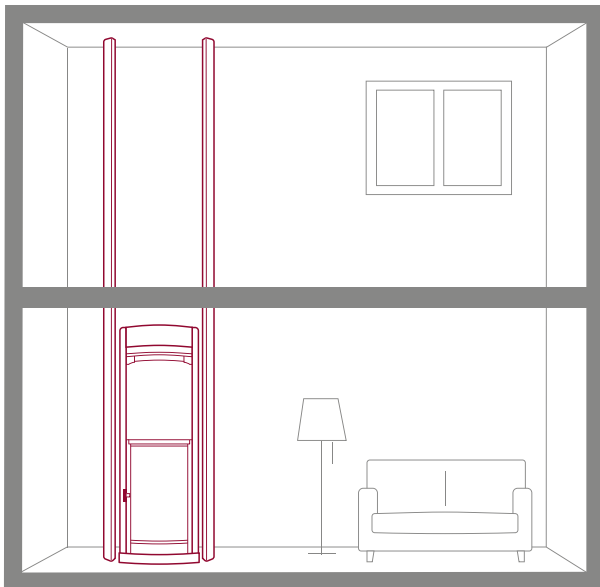

Lifta has installed many Home Lifts that travel through the void. Just create an opening as per the Lifta requirements.

## GALLERY SOLUTION

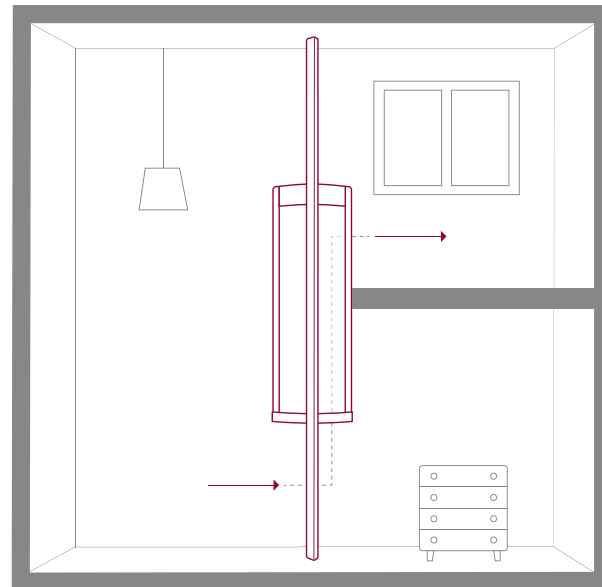

Travel comfortably in an open space: The Lifta Home Lift can also negate the distance between floors by operating in the centre of a stairwell or in a gallery. As a result, you will be utilising your space in the best possible way.

## SHAFT SOLUTION

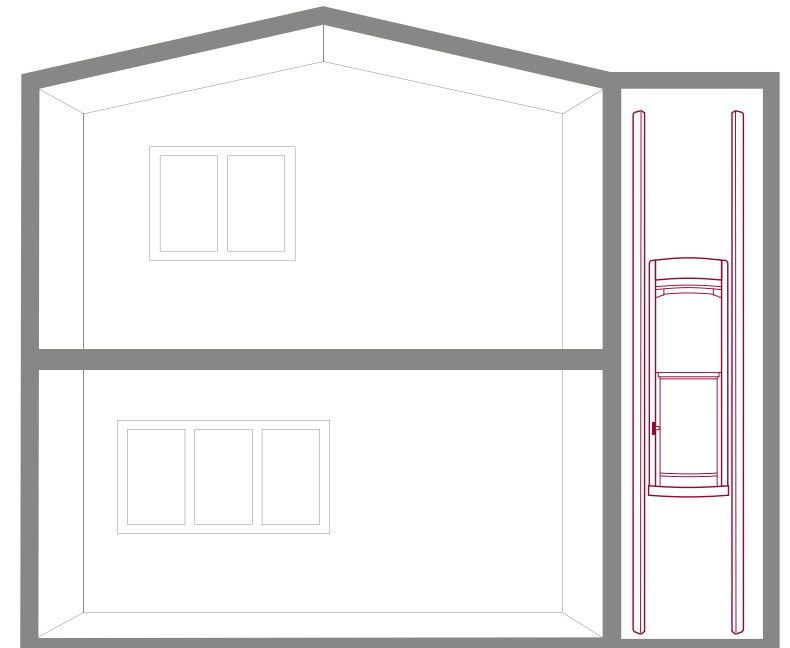

Can not find a suitable space in your house for the lift? Not to worry, we can also install your Home Lift in a weather proof shaft.

## OTHER SOLUTIONS

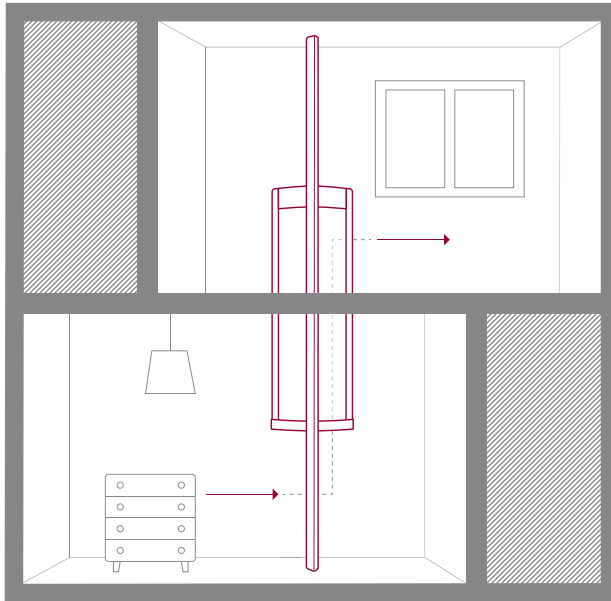

Enter at the front and exit from the rear: The Lifta Trio's optional two-door cabin offers an abundance of other options for connecting floors.

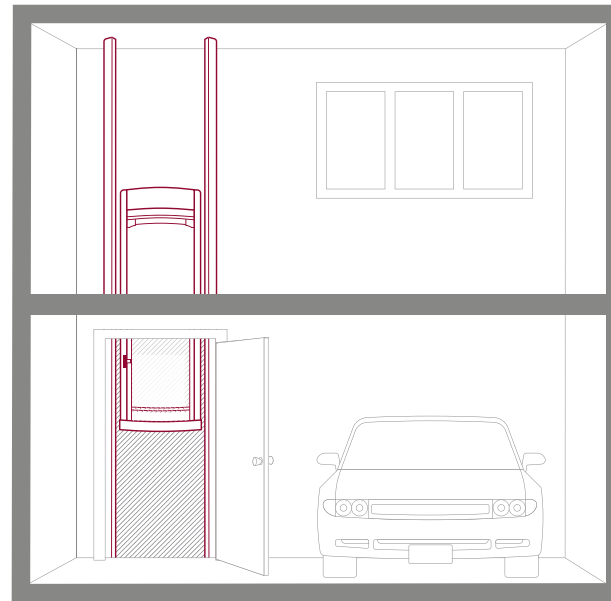

Conveniently glide from your hallway, cellar or garage straight into your living space: A Lifta Home Lift will safely take you to your car and back.

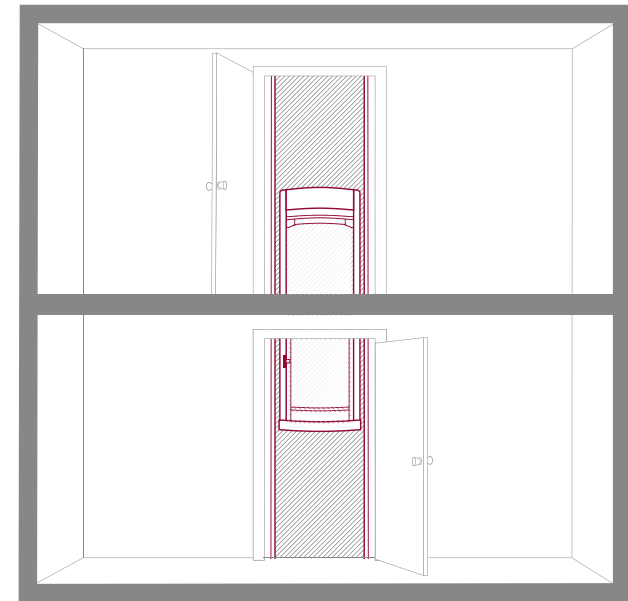

Is space limited? The Lifta Home Lift will even fit into a storeroom or a wall unit. The possibilities for creative installation ideas are almost endless.

# Service

Lifta Home Lifts are unique lift solutions that can be fitted beautifully in any home. All of our models meet the national and international regulations and fall under the Machinery Directive (2006/42/EC). Furthermore, all of our installations are registered with the department of labour.

The Home lifts only require one annual service, which includes an extensive check up on all electronic and mechanical components of the lift. Additionally, we make sure that all safety features around the lift are fully functional.

If you are interested in our servicing plans, please do not hesitate to ask your Lifta expert.



## CAN A LIFTA HOME LIFT BE FITTED IN YOUR HOME?

One of our technical experts will provide you with comprehensive advice during a consultation that is completely without obligation. Call us now to arrange an obligation free appointment at your home.

**0807 373 737**

Lifta 

# Contact us



Book an obligation-free consultation now!  
Call us toll-free:

**0807 373 737**

[www.lifta.co.za](http://www.lifta.co.za)

Lifta Stairlifts SA (PTY) Ltd  
2nd Floor  
130 Adderley Street  
8000 Cape Town

